

SAAB 9-5 ABS CONTROL MODULE REMOVAL

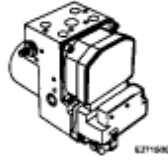

Electronic Module Top Electronic Module Removed Only

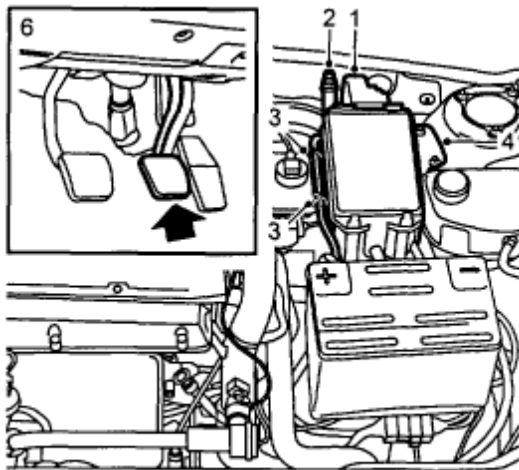

E521R009

To remove

1. Release the Maxi-fuse holder.
2. Unplug the electrical connector on the anti-theft alarm.
3. Cut off the cable ties securing the positive battery cable to the main fuse box.
4. Undo the nuts and move the main fuse box out of the way.
5. Suspend the main fuse box from a cable tie.

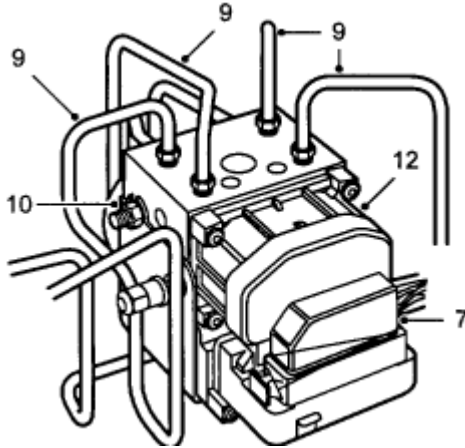

There are 6 torx type screws that hold the module to the hydraulic assembly; we are not removing the hydraulic assembly only the upper electronic module. With the harness plug and torx screws removed lift module off the hydraulic assembly carefully, There are solenoid probes in the abs module they are delicate, once removed tape a piece of thick cardboard to the bottom of module, on the hydraulic assembly you will see probes, these need to be protected from the environment, you can use plastic bag with duct duct seems to work well, When you receive your rebuilt module back replace the module to the surface it will mate flat if there are no obstructions ,start with the two inner torx screw snug them then the lower two snug them and then the upper two snug them and repeat this ,(DO NOT OVER TIGHTEN) we do not want to break them.

When re-installed all lights should go out on dash that pertain the abs or tracs system if they do not try driving your vehicle upwards of 15 mph for at least 15 minutes, When lights are on you do not have any BS braking system, your standard braking system will operate as normal, If lights still not go out then codes will need to extracted and read, these error codes will inform you if there are other issues in the vehicle, generally a failed wheel speed sensor located at each wheel will cause abs failure light to illuminate and abs failure, For Information dealing with abs lights not turning off please email us at tech@autoecu.com.

Thank You

Auto & Truck Electronics Tech Team

www.autoecu.com