

## GM TRUCK SUV INSTRUMENT CLUSTER REMOVAL

Remove the instrument panel cluster (IPC) trim  
plate bezel;

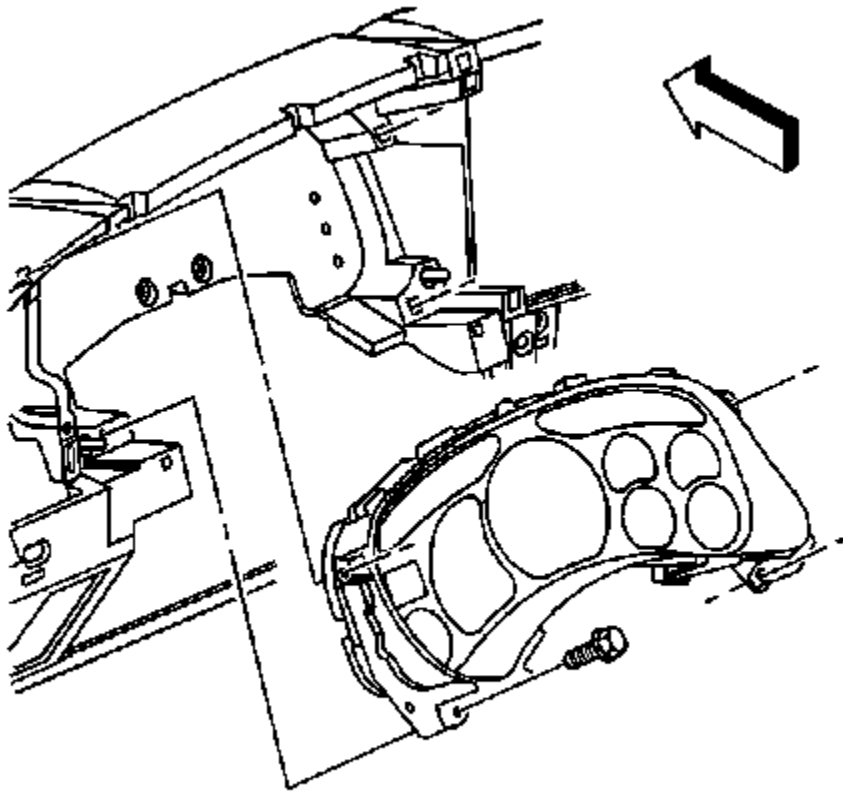

Remove the screws that retain the IPC to the instrument  
panel (I/P) assembly

[www.autoecu.com](http://www.autoecu.com)

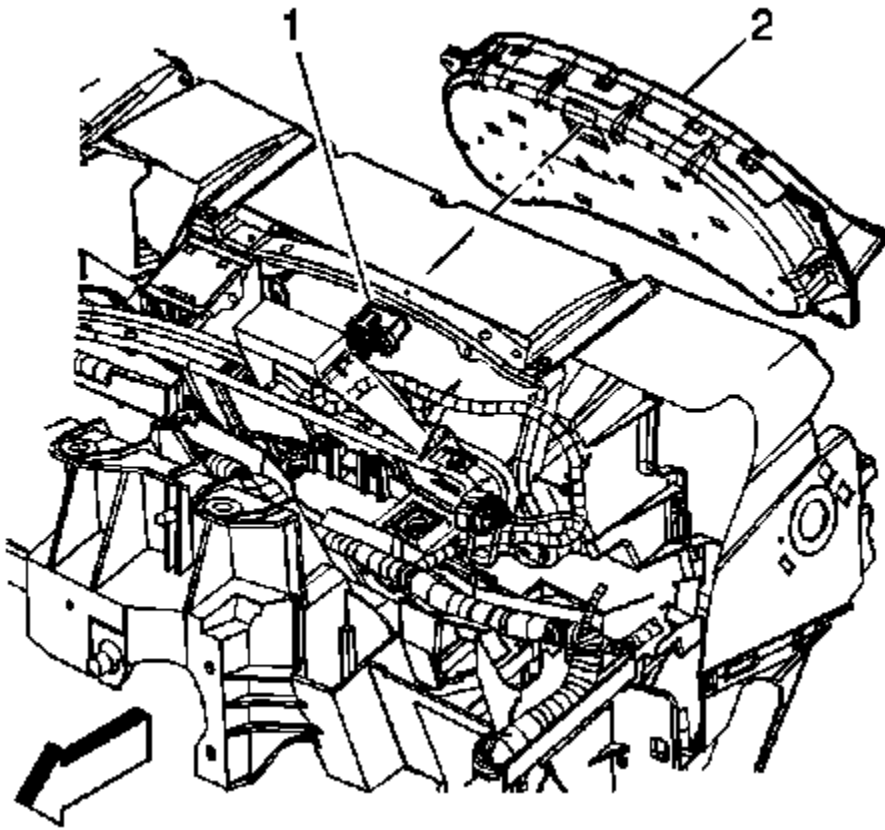

3. Remove the IPC (2) from the vehicle by tilting the bottom of the cluster outward.
4. Disconnect the IPC harness (1) from the IPC.

[www.autoecu.com](http://www.autoecu.com)

## INSTALLATION PROCEDURE

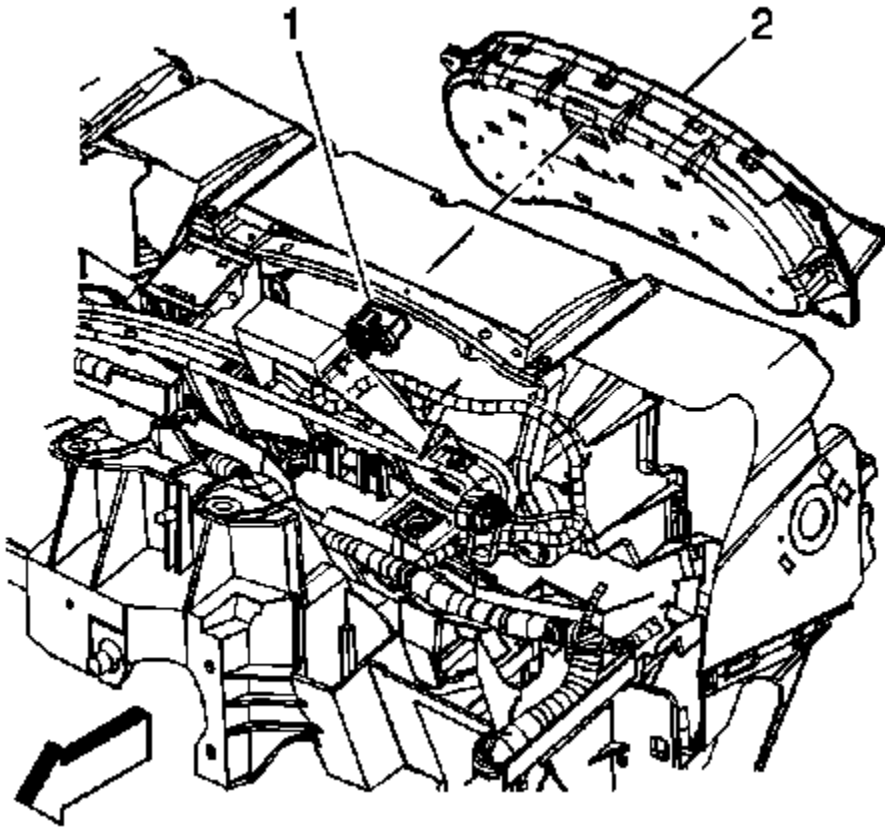

**1. Connect the IPC harness (1) to the IPC (2).**

[www.autoecu.com](http://www.autoecu.com)

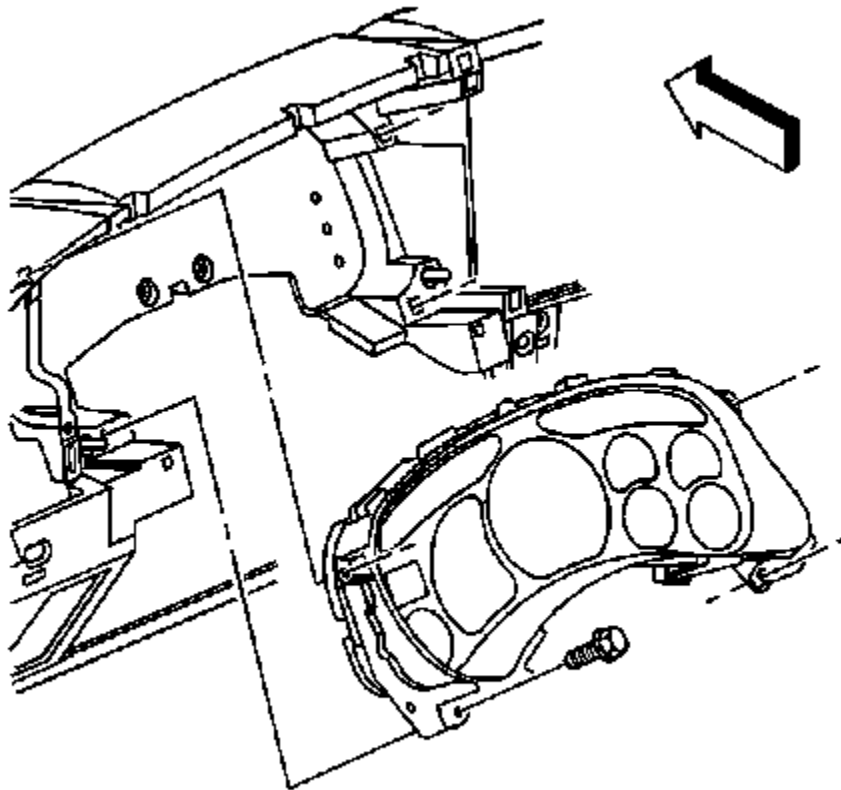

2. **Install the IPC onto the I/P with the screws. Tilt the top of the cluster into the retainer first to avoid damaging the flexible circuit connections.**
3. **Install the screws that retain the IPC to the I/P assembly.**

## **BEZEL REMOVAL**

### **BEZEL REPLACEMENT - INSTRUMENT PANEL (I/P) CLUSTER**

#### **REMOVAL PROCEDURE**

1. Tilt the steering wheel to the full down position.
2. Remove the left closeout/insulator panel .
3. Remove the knee bolster trim panel.

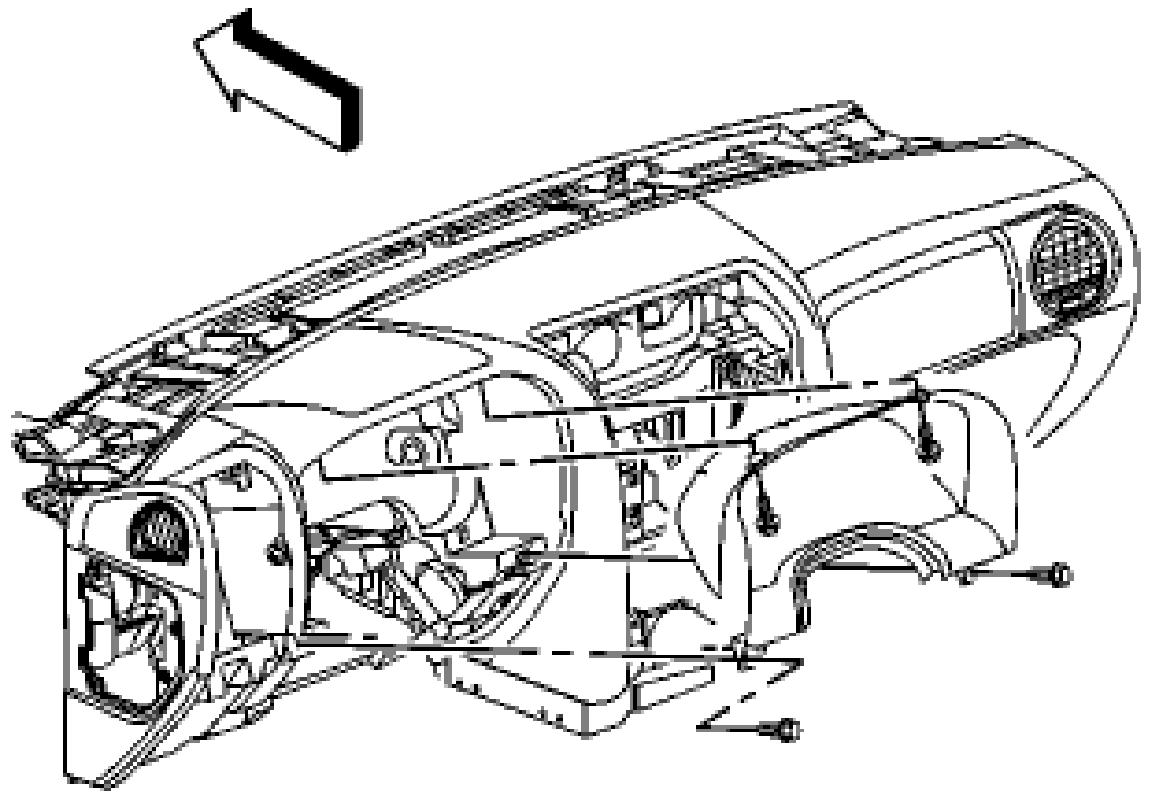

4. Remove the screws that retain the bezel to the instrument panel.
5. Remove the bezel from the instrument panel.

