

## **Anti-Lock Brake System (ABS) Module**

### **Removal and Installation**

**WARNING:** Brake fluid contains polyglycol ethers and polyglycols. Avoid contact with eyes. Wash hands thoroughly after handling. If brake fluid contacts eyes, flush eyes with running water for 15 minutes. Get medical attention if irritation persists. If taken internally, drink water and induce vomiting. Get medical attention immediately. Failure to follow these instructions may result in personal injury.

**CAUTION:** Brake fluid is harmful to painted and plastic surfaces. If brake fluid is spilled onto a painted or plastic surface, immediately wash it with water.

**CAUTION:** Electronic modules are sensitive to electrical charges. The ABS module can be damaged if exposed to these charges.

**NOTE:** When installing a new ABS module, it must be configured (using vehicle as-built data) and calibrated. Follow the diagnostic tool directions for the configuration and calibration procedures.

1. Remove the hydraulic control unit (HCU)
2. Remove the parts in the order indicated in the following illustration and table.

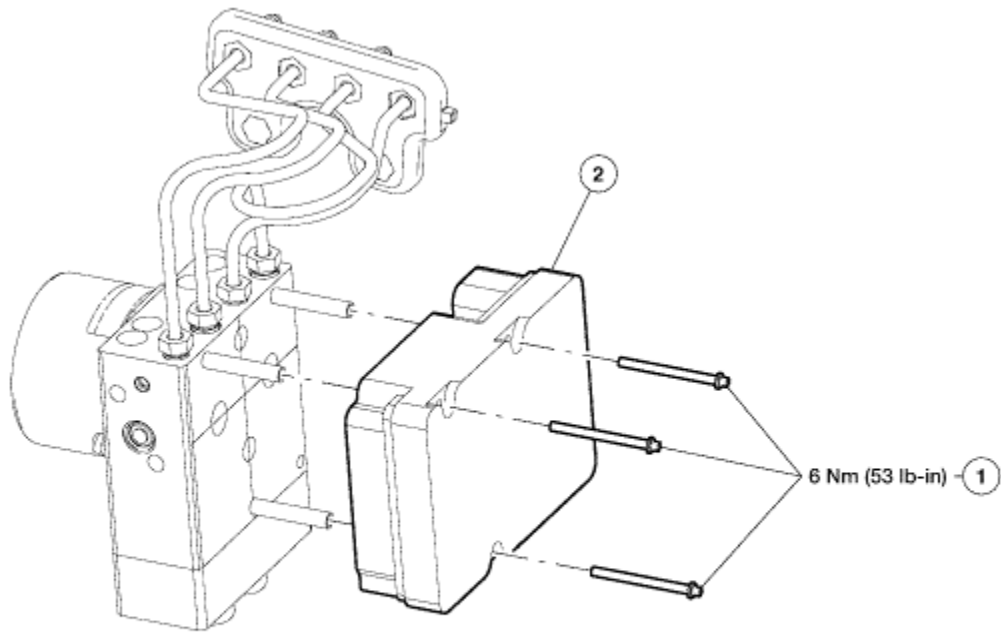

A0082325

Item	Description
1	ABS module screws
2	ABS module

To ship to us visit our website @ [www.autoecu.com](http://www.autoecu.com) Click the Forms tab then click the R&R form, Complete the form and include it together with the part and ship to our address on the form.

AUTOMOTIVE SCIENTIFIC INC.  
[WWW.AUTOECU.COM](http://WWW.AUTOECU.COM)

1-866-983-6688